

PowerKit Engine3M10 Series

General Specifications

Bore & Stroke	105x120 mm
Displacement	3.12 L
Cylinder Number	3
Compression Ratio	15.5:1
Fuel System	Mechanical Pump
Governor	Mechanic/Electronic
Aspiration	NA/T/TA
Emission Standard	EU Stage II



Engine Speed	Engine Output		Typical Generator Output(ESP)	Engine Speed	Engine Output		Typical Generator Output(ESP)
	Prime(PRP)	Standby(ESP)			Prime(PRP)	Standby(ESP)	
(rpm)	kWm	kWm	kWe/kVA	(rpm)	kWm	kWm	kWe/kVA
1500	30	33	26/33	1800	36	40	33/42
1500	45	50	44/55	1800	50	55	44/55
1500	55	61	53/66	1800	64	70	60/75

Standard Equipment

Engine and block

- Cast iron gantry type structure block
- One-piece forged crankshaft
- Separate cast iron cylinder heads and wet liners
- Aluminium alloy pistons with gallery oil cooling

Cooling system

- Thermostatically-controlled system with belt driven coolant pump and pusher fan

Lubrication system

- Spin-on full-flow lub oil filter

Special design connector for oil heater and drawing off oil pump

Fuel system

- In-line AD fuel injection pump
- Duplex fine filter for better efficiency

Air intake and exhaust system

- High performance silencer as standard
- Stainless steel exhaust manifold shield for heat isolating

Electrical system

- 12V electric starter motors and battery charging alternator
- Standard sensor connector

Flywheel and housing

- SAE3 flywheel housing and 11.5" flywheel

Dimensions and Weight

	NA	T	TA
Length	1152 mm	1129 mm	1241mm
Width	738 mm	738 mm	839 mm
Height	996 mm	1030 mm	1030 mm
Net Weight	430kg	455kg	480kg

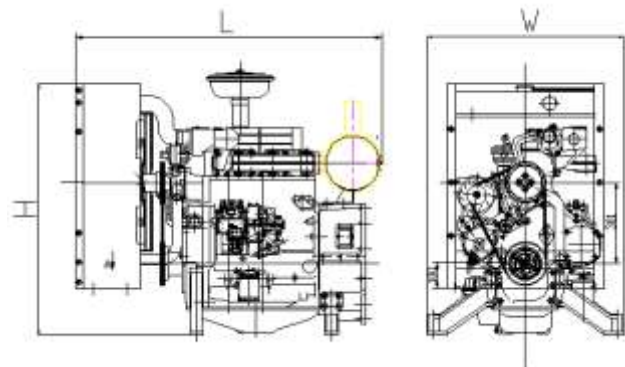

G-Drive Engine3M10 Series

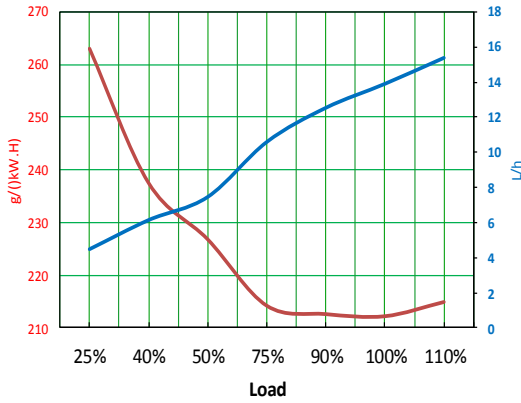

3M10G66/5e2-55kW/1500rpm

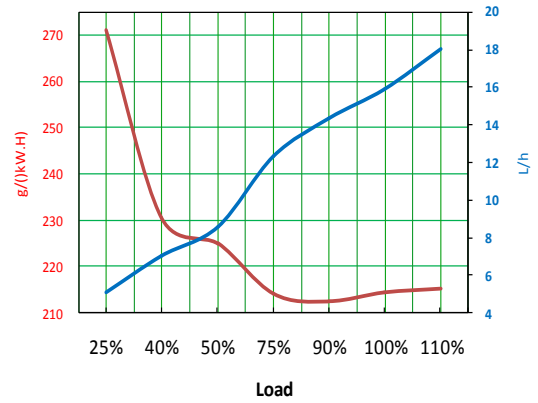

3M10G50/6e2-64kW/1800rpm

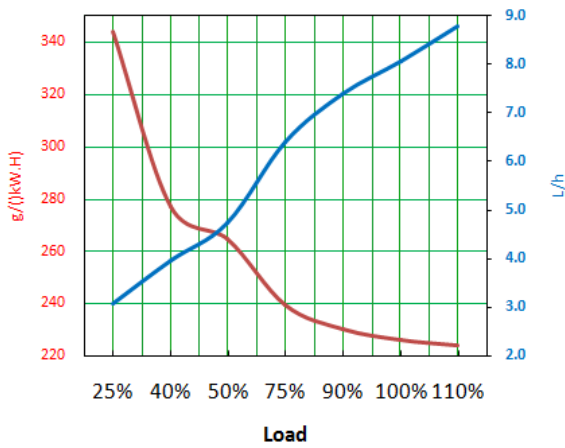

3M10G33/5-30kW/1500rpm

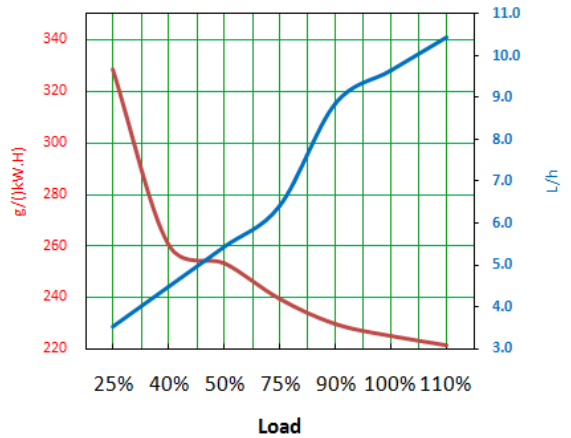

3M10G30/6-36kW/1800rpm

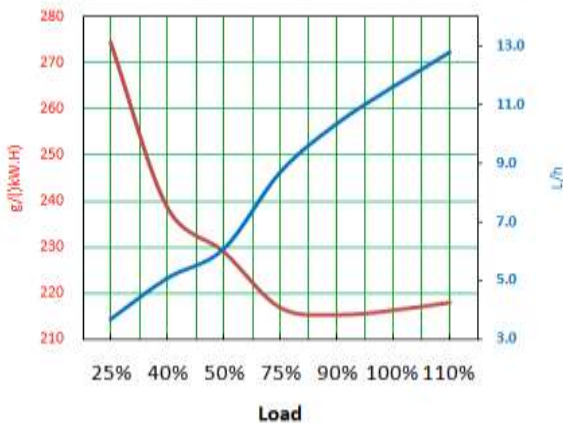

3M10G55/5-45kW/1500rpm

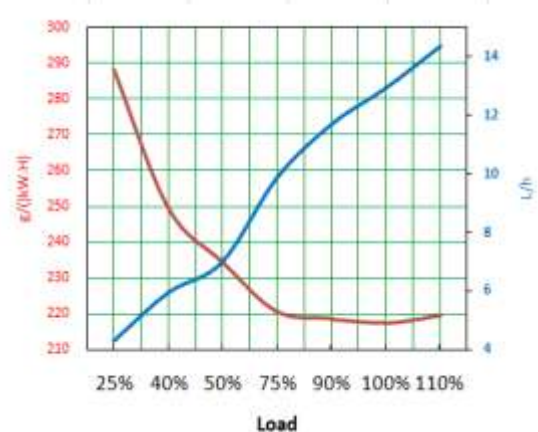

3M10G40/6-50kW/1800rpm

Manufacturer:
Address:

SOCIETE INTERNATIONALE DES MOTEURS BAUDOUIN
Technoparc du Bregadan
13260 Cassis, FRANCE
<http://www.baudouin.com>